

052404-510901-(02)

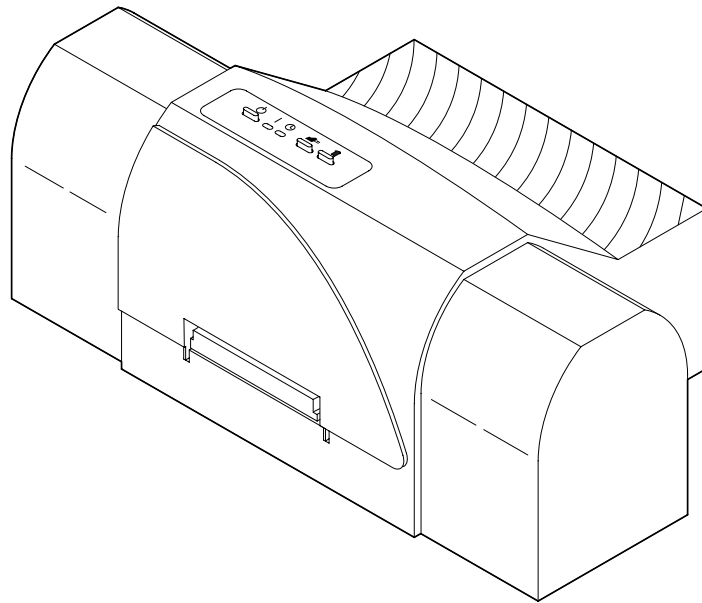

# OptiEC Pro Printer 6

---

OptiEC Pro Printer 6 User's Manual

© 2001-2004 All rights reserved.

**NOTICES:** THE INFORMATION IN THIS DOCUMENT IS SUBJECT TO CHANGE WITHOUT NOTICE.

NO WARRANTY OF ANY KIND IS MADE WITH REGARD TO THIS MATERIAL, INCLUDING, BUT NOT LIMITED TO, THE IMPLIED WARRANTIES OF MERCHANTABILITY AND FITNESS FOR A PARTICULAR PURPOSE. No liability is assumed for errors contained herein or for incidental or consequential damages in connection with the furnishing, performance, or use of this material. This document contains proprietary information which is protected by copyright. All rights are reserved. No part of this document may be photocopied, reproduced, or translated into another language without prior written consent.

**Trademark Acknowledgments:** IBM is a registered trademark of International Business Machines Corporation. Windows is a trademark of Microsoft Corporation. All other trademarks are the property of their respective owners. CandelaColor® Charged by Pictographics is a registered trademark of Pictographics International Corporation.

#### Printing History

Edition 2.0, #052404, © Copyright 2001-2004, All rights reserved.

**FCC Compliance Statement:** This device complies with part 15 of the FCC rules. Operation is subject to the following two conditions: (1) this device may not cause harmful interference, and (2) this device must accept any interference received, including interference that may cause undesired operation.

**For Users in the United States:** This equipment has been tested and found to comply with the limits for a Class B digital device, pursuant to Part 15 of the FCC Rules. These limits are designed to provide reasonable protection against harmful interference in a residential installation. This equipment generates, uses, and can radiate radio frequency energy and, if not installed and used in accordance with the instructions, may cause harmful interference to radio communications. However, there is no guarantee that interference will not occur in a particular installation. If this equipment does cause harmful interference to radio or television reception, which can be determined by turning the equipment off and on, the user is encouraged to try to correct the interference by one or more of the following measures:

- Re-orient or relocate the receiving antenna.
- Increase the separation between the equipment and receiver.
- Connect the equipment into an outlet on a circuit different from that to which the receiver is connected.
- Consult the dealer or an experienced radio/TV technician for help.

Use of a shielded cable is required to comply with the Class B limits of Part 15 of the FCC Rules. You are cautioned that any changes or modifications not expressly approved in this manual could void your authority to operate and/or obtain warranty service for this equipment.

Within the U.S., this product is intended to be supplied by a UL Listed Direct Plug-in Power Unit marked Class 2 and rated 30 Vdc, 830 mA or 1.0A.

**For Users in Canada:** This digital apparatus does not exceed the Class B limits for radio noise for digital apparatus set out on the Radio Interference Regulations of the Canadian Department of Communications. Le présent appareil numérique n'émet pas de bruits radioélectriques dépassant les limites applicables aux appareils numériques de la class B prescrites dans le Règlement sur le brouillage radioélectrique édicté par le ministère des Communications du Canada.

#### CAUTION!

TO PREVENT FIRE OR SHOCK HAZARD, DO NOT EXPOSE THE UNIT TO RAIN OR MOISTURE. TO REDUCE THE RISK OF ELECTRIC SHOCK, DO NOT REMOVE EXTERIOR PANELS. NO USER-SERVICEABLE PARTS INSIDE. REFER SERVICING TO QUALIFIED SERVICE PERSONNEL. OPERATE THE UNIT WITH ONLY THE PROPER ELECTRICAL SPECIFICATIONS AS LABELED ON THE PRINTER AND AC ADAPTER

# Table of Contents

<b>Section 1: Getting Started</b> .....	<b>1</b>
A. Choosing a Good Location .....	1
B. Unpacking and Inspection.....	1
C. Identifying the Parts .....	2
D. Applying Power .....	3
<b>Section 2: Ink Cartridges and Printable Media</b> .....	<b>4</b>
A. About Ink Cartridges and Printable Media .....	4
B. Installing an Ink Cartridge .....	4
C. Loading Blank Media .....	6
D. Printing a Self Test.....	7
E. Replacing or Switching Ink Cartridges.....	7
<b>Section 3: Using the OptiEC Pro Printer 6 with Windows</b> .....	<b>11</b>
A. Installing the Printer.....	11
B. Setting Up the Printer Driver.....	13
C. Printing a Disc.....	21
D. Creating a Print File (*.prn).....	22
E. Creating PRN Files in SureThing CD Labeler .....	23
<b>Section 4: Interpreting the Printer Indicator Lights</b> .....	<b>24</b>
<b>Section 5: Maintaining the Printer</b> .....	<b>26</b>
A. Cleaning the Ink Cartridge Nozzles .....	26
B. Cleaning the Media Tray and Printer Casing.....	26
C. Clearing a Media Jam.....	26
D. Technical Support .....	26
<b>Section 6: Technical Specifications</b> .....	<b>27</b>
<b>Appendix A: Interfacing Information</b> .....	<b>28</b>
A. Introduction .....	28
B. 6-Pin Minicircular Auxiliary Interface.....	29
<b>Index</b> .....	<b>30</b>



# Section 1: Getting Started

---

## THANK YOU...

...for choosing the OptiEC Pro Printer 6. This printer is the perfect way for you to label all of your custom CDs and DVDs quickly, easily, and with a touch of class. The OptiEC Pro Printer 6 lets you print razor-sharp text, vibrant spot colors, and even stunning photo-realistic photographs directly onto the surface of printable discs. Operation is simple, quality is high, and printed images are durable and highly smudge-resistant. To begin using the printer, please refer to the remainder of this manual. This User's Manual is your complete step-by-step guide to quickly and easily setting up and printing with your new OptiEC Pro Printer 6!

---

## A. CHOOSING A GOOD LOCATION

- Place the printer in a location with adequate air circulation to prevent internal heat build up.
- Do not place the printer near heat sources such as radiators or air ducts, or in a place subject to direct sunlight, excessive dust, mechanical vibration or shock.
- Allow for adequate clearance in front of the printer to accommodate the length of the unit with its Disc Tray open.

---

## B. UNPACKING AND INSPECTION

While unpacking your printer, inspect the carton to ensure that no damage has occurred during shipping. Make sure that all supplied accessories are included with your unit. The following items should be included:

- Printer
- PowerAdapter
- Printer Software CD
- CMY Color Ink Cartridge, Reorder #53321
- Photo Color Ink Cartridge, Reorder #53324
- This manual and other printed information

Save the carton and packing materials. They will come in handy when transporting the printer.

### C. IDENTIFYING THE PARTS

This illustration shows the extended Disc Tray and all of the control buttons and LED indicator lights found on the printer.

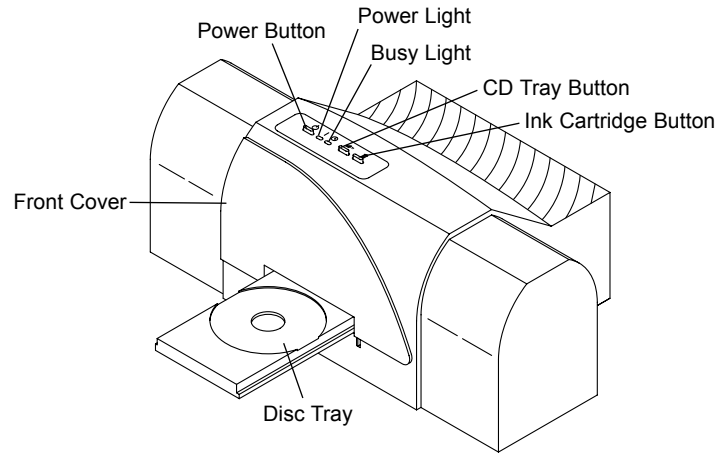

The  **Power Button** turns the printer's power ON and OFF.



This button also serves to cancel the current print job if a print error occurs and to reset the printer for the next print job.

The  **Disc Tray Button** opens or closes the Disc Tray for loading and ejecting discs.

The  **Ink Cartridge Button** positions the Cartridge Carrier for easy ink cartridge replacement.

The  **Power Light** indicates that power is ON. The  **Busy Light** indicates that the printer is printing, processing, or is in some way busy. Both of these lights can also indicate several other printer conditions. For complete information on these lights, please refer to Section 4.

This illustration shows the input ports found on the rear panel of the printer. Note that the printer's auxiliary port is for use with auto loaders and automatic duplicators only, which are sold separately. For more information on the interface ports, please refer to Appendix B.

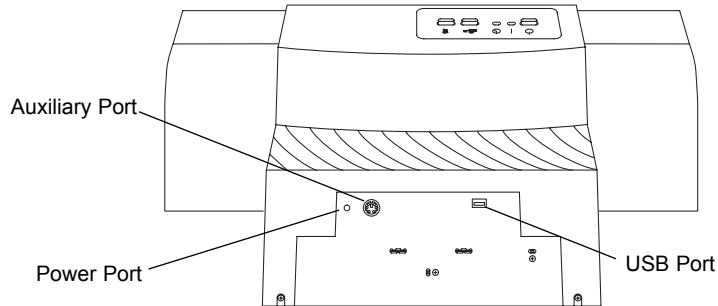

#### D. APPLYING POWER

1. Locate the power adapter supplied with your printer.
2. Place one end of the adapter cord into the power port on the rear panel of the printer.

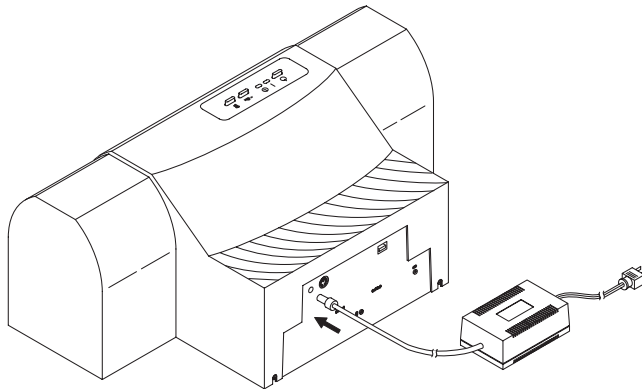

3. Plug the power cord of the adapter into an available wall outlet. Once the power cord is connected, the printer will automatically turn ON.

## Section 2: Ink Cartridges and Printable CDs

### A. ABOUT INK CARTRIDGES AND PRINTABLE CDS

For photographic 6 color printing, two cartridges are needed. First is a CMY (cyan, magenta and yellow) color cartridge. The second is a Kcm (black, light cyan and light magenta) Photo color cartridge. These cartridges contain the process colors which combine to produce 16.7 million printable colors. A monochrome ink cartridge is also available for fast, inexpensive black-and-white printing or can be used with the CMY color cartridge for 4-color CMYK printing.

With all of these ink cartridges, you can print directly onto virtually any brand of inkjet printable-surface media. Since different brands of discs have different printable coatings, however, you may need to adjust the printer driver settings to accommodate your specific brand of media. Refer to Section 3 for further printer driver information.

Due to the wide variety of inkjet printable-surface media, you may find that certain brands of discs provide higher print quality than others. For maximum print quality, use media authorized by the printer manufacturer. Contact your local OptiEC Pro Printer reseller or contact the printer manufacturer directly for selection and pricing on all printer supplies and accessories.

### B. INSTALLING THE INK CARTRIDGES

1. With the Disc Tray closed, open the printer's front cover by pulling down on its top-left corner.

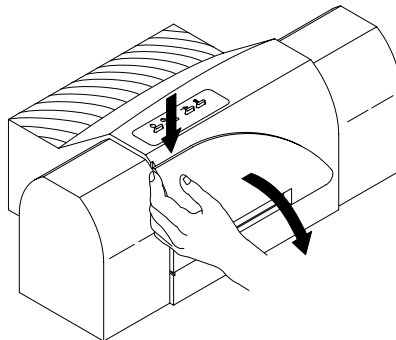

2. Remove the CMY color ink cartridge from its packaging.
3. Slowly remove the tape covering the cartridge's printhead, being careful to avoid damaging or removing the barcode label on the underside of the cartridge.

**DO NOT TOUCH THE COPPER AREA!**

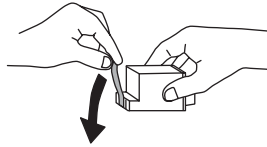

4. Press and release the  Ink Cartridge button to move the carrier to the load position.
5. Insert the CMY color ink cartridge into the left cartridge carrier position, copper end first.

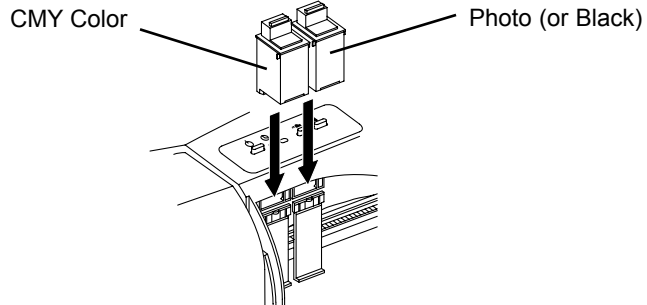

6. Push the cartridge back until it snaps into place.

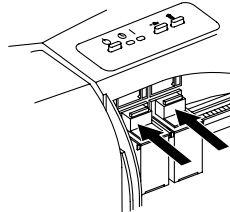

7. Repeat steps 2 through 6 for the Photo color (or Black cartridge), placing it in the right cartridge carrier position.
8. Close the printer's front cover. If you leave the door open, ambient light can interfere with proper cartridge initialization.
9. Press and release the  Ink Cartridge button again to reset the cartridge carrier.

**NOTE:** When changing to subsequent new cartridges, refer to Section



E.

### C. LOADING BLANK MEDIA

The OptiEC Pro Printer 6 is capable of printing onto a variety of media. Each disc is loaded one at a time, before the start of a print job.

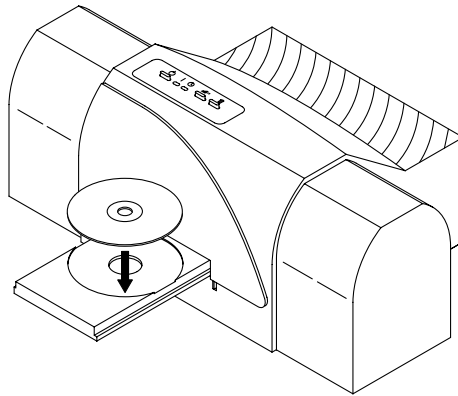
Loading  
a Blank  
Disc





1. With the printer's front cover shut, press and release the  Disc Tray button.
2. Once the Disc Tray is fully extended, place the blank disc onto the tray with the printable side facing upward. Handle the disc only along its edges and **DO NOT** touch its printable surface.
3. Press and release the  Disc Tray button to close the Disc Tray. If you wish, you may also leave the Disc Tray open and it will automatically close at the start of the print job. Once the disc has been printed, the Disc Tray will automatically re-open so the next blank disc can be loaded.

---

#### D. PRINTING A SELF TEST

Now that the printer is set up and print supplies are loaded, a self test should be performed to check for proper operation of the printer.

1. If power is ON, turn it OFF now using the Power button. The Power light should be OFF. Verify that print supplies are installed and close the printer's Disc Tray.
2. With the printer's front cover shut, press and hold the  Disc Tray button as you turn the printer power ON.
3. Continue to hold the  Disc Tray button down for a few seconds, until you hear the self test begin to print.

---

#### E. REPLACING OR SWITCHING INK CARTRIDGES

Once you begin using your OptiEC Pro Printer 6 on a regular basis, you will eventually need to replace an empty ink cartridge. Please refer to the following steps:

1. With the Disc Tray closed, open the printer's front cover by pulling down on its top-left corner.

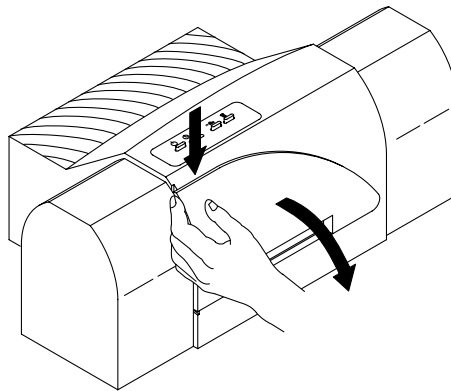

2. If installing a new, replacement ink cartridge, slowly remove the tape covering the cartridge's printhead, being careful to avoid damaging or removing the barcode label on the underside of the cartridge.  
**DO NOT TOUCH THE COPPER AREA!**

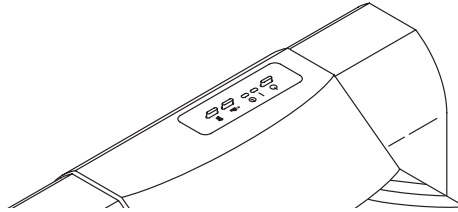

3. From within the printer driver setup window, click on the **Cartridge** button and then on the **Change** button to move the carrier to the load position. Note that the printer driver must be installed and that the printer must be connected to your computer (see Section 3) in order to complete this step.

If you prefer, you may instead press the Ink Cartridge button on the top of the printer.

4. Remove the installed ink cartridge by grasping the top of the cartridge and firmly pulling it straight toward you. You will hear the cartridge snap out of position. Remove it from the printer.

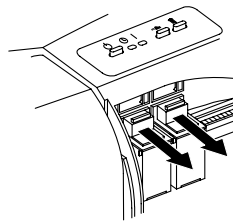

5. Insert the replacement or alternate ink cartridge into the cartridge carrier, copper-end first.

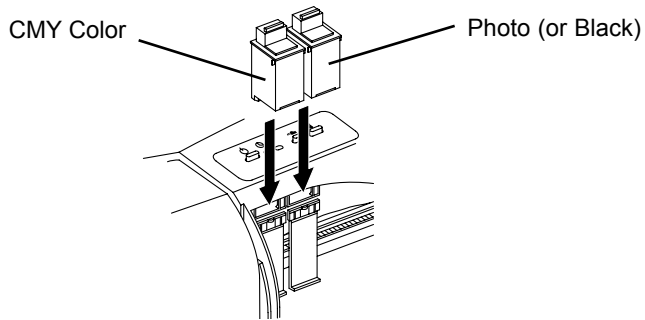

6. Push the cartridge back until it snaps into place.

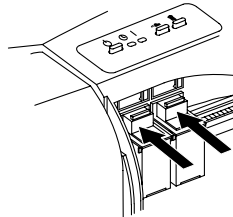

7. Close the printer's front cover.
8. Go back to the printer driver setup window and click on either the **New Color, New Black or Photo, or Used Cartridge** button to indicate whether you installed a fresh, new cartridge or simply switched between a previously used cartridge.  
The cartridge carrier will return to its home position.  
See Section 3 for more information on these buttons.

*NOTE: When you choose New Cartridge, the ink levels are cleared and the ink level counter will go back to full capacity (for either color or monochrome). The ink levels reflected in the printer driver are an estimate of the ink level in the cartridge. The levels are not actually read from the cartridges themselves, but are based on an estimated number of ink droplets used in printing deducted from a known amount of droplets in a new cartridge.*

*NOTE: The ink cartridges you use with your printer may require periodic general maintenance to ensure optimal print quality. If your prints show banding or lines through the image, left to right on the printed disc, you should clean the ink cartridge as described in your User's Manual. Please note that it may take more than one cleaning to unclog the tiny nozzles that make up the ink cartridge's print head.*

*If the cleaning process as described in the manual does not improve print quality, moisten a cloth with isopropyl alcohol and gently dab the brass colored tip of the cartridge until clean of any dried ink until you get smooth ink flow from all three colors. The moisture helps to draw the ink out of the cartridge. It is very important to blot the cartridge very gently; wiping or scrubbing the print head could easily damage the cartridge.*

## Section 3: Using the OptiEC Pro Printer 6

### A. INSTALLING THE PRINTER

The OptiEC Pro Printer 6 can be used with virtually any Windows application program. This is accomplished by installing in Windows what is called a “printer driver.” The printer driver is simply software which gives the printer all the information needed for printing. Use the following steps to install the printer driver.

*NOTE: This section of the Operator’s Manual assumes that you are already familiar with Windows and know how it operates. If you are not yet familiar with Windows, consult the appropriate Microsoft documentation to become familiar with the basics of Windows before proceeding.*

To install the printer driver into Windows 2000/XP, refer to the following:

1. Insert the included CD into your computer’s CD-ROM drive. The installer program should launch automatically after a few moments. If it does not, click **Start > My Computer** then right click on the OptiEC Pro Printer 6 icon and select AutoPlay.
2. Click the **Quick Install** button and follow the on-screen instructions.
3. Connect the printer to your computer. The printer is equipped with a standard 4 Pin USB port. This port is the means through which it receives data from your computer. To connect the printer to your computer, use the included USB cable and

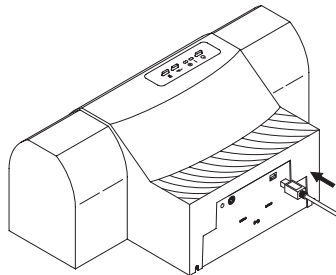

refer to the following steps:

- A. Connect the square shaped side of the USB cable to

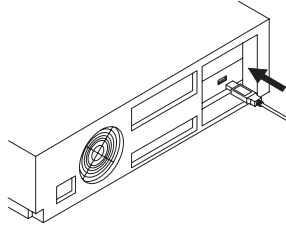

the printer.

- B. Connect the rectangular shaped side of USB cable to an available USB port on your computer.  
C. The printer must have its Power light illuminated to receive data. If the light is not on, press the Power button.  
4. Once the printer has been turned on and connected to the

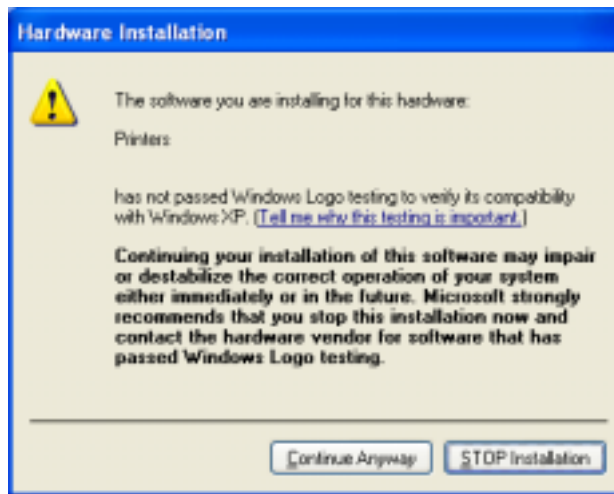

PC, after a few moments Windows should detect and attempt to install the printer. Click **Next**, you will be



*CD/DVD Printer 6*

prompted with a dialog box like the one shown here:

5. Once installed, the “OptiEC Pro Printer 6” icon will appear in the Printer’s folder:

**IMPORTANT!** *During installation of the Windows 2000/XP driver you must de-select (uncheck) the check box “Automatically detect and install my plug and play printer”.*

**NOTE:** *Before installing updated printer driver versions, always delete the existing printer driver version from your system. To do this, simply select the printer driver icon from within the Printers folder, and press the Delete key. After installing the new printer driver you will need to re-boot if you are using Windows XP.*

---

## B. SETTING UP THE PRINTER DRIVER

Once the printer driver has been successfully installed, you will need to set the driver up with the appropriate print options. Refer to the following steps to change or verify your printer driver options:

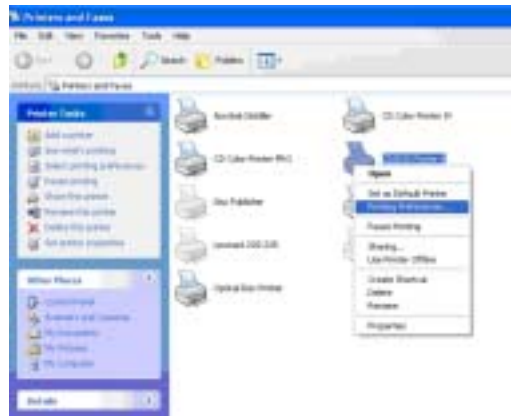

1. Click the **Start** button, then click **Printers and Faxes** (also



found under Control Panel on XP Home or Windows 2000). Right click on the OptiEC Pro Printer 6 Icon and select Printing Preferences.

2. Click on the **Advanced** button for more driver settings.

*NOTE: Most applications allow you to change these same printer driver options from their "Print" and/or "Printer Setup" screens. This means that you don't have to go back to the main printer setup window each time you want to change a setting or option in the printer driver. These applications will usually give you the same choices and options, but in a slightly altered format. Most applications do not save your printer driver option changes, but instead only use your changes for the current image.*

3. In this window you will see all of the driver options. Refer to the remainder of this section for a description of each printer driver option.

#### Paper Size

The Paper Size option will be set to Disc 120mm for printing onto printable surface CDs, DVDs. When sizing your images for printing, keep in mind that media has the maximum printable area of 119.7 mm. In the drop down Media Type menu you can also select Custom, which allows you to increase or decrease your imaging area.

### Orientation

This defaults to Portrait which will work for all round disc types. When the Paper Size is set to a non-round disc type such as Business Card or Hockey Rink disc, this will automatically change to Landscape.

### Non-printable Outer Margin

This setting controls the outer diameter of your print area. By default, the driver is allowing a 1.5mm margin around the disc. Increasing the number in this setting will make a larger non-printed border around your disc, while a smaller number will make a smaller non-printed margin. While this is adjustable to allow for printing to the edge, take care to not print on uncoated portions of the disc as ink in these areas will not dry and could spin off of the disc in a drive.

### Resolution

Select the appropriate print quality option for your image. Keep in mind that Normal 600 provides the lowest quality but fastest print, and that Ultra Photo 4800 provides the highest quality but slowest print. You may wish to experiment with these options to see which one is best for your particular CD media and print quality parameters.

### Ink Cartridge

This setting defaults to Color + Photo which provides the highest quality print utilizing the 6 color printing available in the OptiEC Pro Printer 6. Other options available are Monochrome Black for printing black and white images, Color + Black for printing process 4 color, and Color for utilizing only the CMY color cartridge to print your color images. Please note the highest yield per cartridge and fastest print times of full color images are achieved with the Color setting, while the highest quality images are created using the Color + Photo setting.

### Color Matching

Click on the Color Matching down arrow and choose the color matching option that's right for you. Select **None** if you are more interested in processing speed rather than color accuracy, if you have already color corrected your image for printing, or if you are using some other third party color

matching software.

Select **Algebraic** if you would like the printer driver to make very simple color balance adjustments based on an RGB color model. This option gives you more natural looking images without actually utilizing any specific color matching software. Select **PrimaColor** to enable color matching profiles written specifically for the OptiEC Pro Printer 6. The PrimaColor by Candela Color Management System automatically adjusts the color of your image according to preconfigured printer profiles and default system profiles. This results in a very precise color match compliant with ICC standards.

Select **Z-Color** to use a factory set color match scheme that is calibrated toward the inks used in the OptiEC Pro Printer 6. Note that the color of the CD surface can affect the outcome of the colors and PrimaColor is optimized for white TuffCoat CD's.

#### Ink Saturation

This option controls the ink saturation of the printed image. When printing onto the printer manufacturer's TuffCoat CD media, this option can be left at its default setting of 50%. When printing onto other brands of printable CD media, you may need to adjust this control in order to optimize the ink saturation for the printable surface of your specific CD media. Click and drag on the slide's box, or click on the left and right arrows to change the ink saturation setting. Moving the slide's box to the left reduces the overall ink saturation, while moving it to the right increases it.

#### Print Black using only Black Cartridge

When using the Color+Black Ink Cartridge Setting the printer will apply full cyan, magenta, yellow and black ink to create black. This makes for a very strong black but also uses more ink than using just black. This option will allow to use only the black ink for black areas allowing for more efficient ink usage.

#### Calibration Options

This section displays options for fine-tuning the position of your printed image, changing the size of a CD's nonprintable center, and also performing a cartridge alignment calibration. The following gives a complete description of each of the Calibration options.

The **Inner Diameter** adjustment sets the size of the non-printable area at the center of the disc. This is measured in .1mm units and defaults to 386 which is a standard center size.

Making this number smaller will allow you to print closer to the center hub, but be aware that ink printing on non printable surfaces at the center of the disc will not dry and can spin off into a drive.

The **Cartridge Alignment** button will perform a test print to

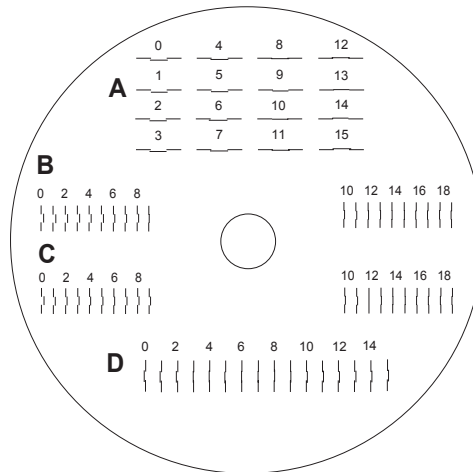

calibrate CMY cartridge to the Kmc photo cartridge as well as the printing and also the color-to-black offset values. Place a CD in the disc tray before clicking on this button. Your print should look something like this:

After the test print is completed, examine the lines displayed after A,B,C and D. Each of the lines will have a number associated with it. Enter the number for the straightest line for A,B,C and D in the space provided in the software.

**Centering the Print Image** contains options to allow you to make sure images are aligned properly on the media.

*NOTE: Your printer comes from the factory pre-calibrated to print the image in the center of the CD. You can use this adjustment if you need to fine-tune this location.*

If you ever wish to verify your factory-calibrated Vertical and Horizontal calibration settings, you can run a simple calibration procedure to assure that your images will be centered when printed on a CD. To do this, refer to the following steps:

1. Verify that a disc and a color ink cartridge are installed in the printer. It is important to use the same disc you

normally use for your publishing because different brands of discs may vary slightly in size. Also, verify that the printer is powered ON and that it is connected to your computer.

2. Click on the **Properties** button. Click **Yes** to perform the test print. (Later, if you want to enter an adjustment without printing a test print, click **No**.) The printer will begin printing the calibration test print.

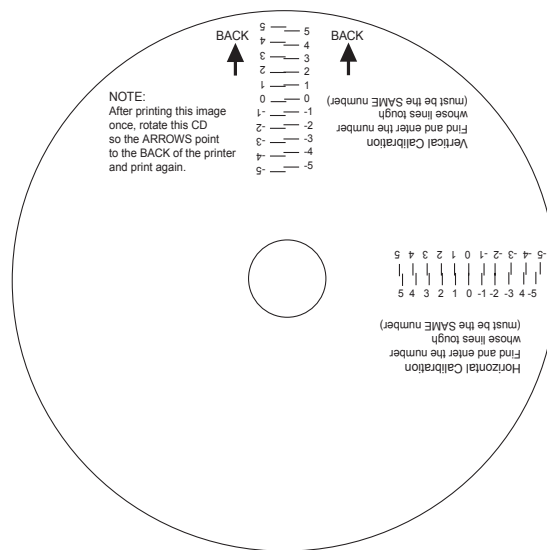
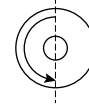

3. When the print is complete, rotate disc 180° and put the disc back in the input bin and repeat step 2 using the same disc.
4. When the second run of the print is complete, you should have a test print that looks something like the following:
5. Along the Vertical axis of the printed disc, find the number whose lines touch. For example, in the above illustration, the number would be 2. Enter that number into the Vertical box of the Calibration window and 0 would be entered for the Horizontal axis.

6. Select the **OK** button. Your images should now be centered when printed on a disc.

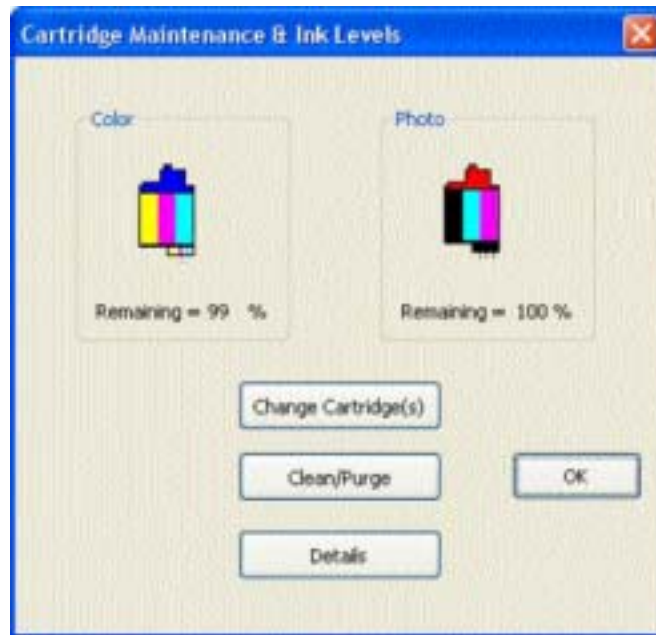

## Clean/Change Cartridges and Check Ink Levels

Select the Properties button here to display the current ink levels as well as options for cleaning and changing cartridges.

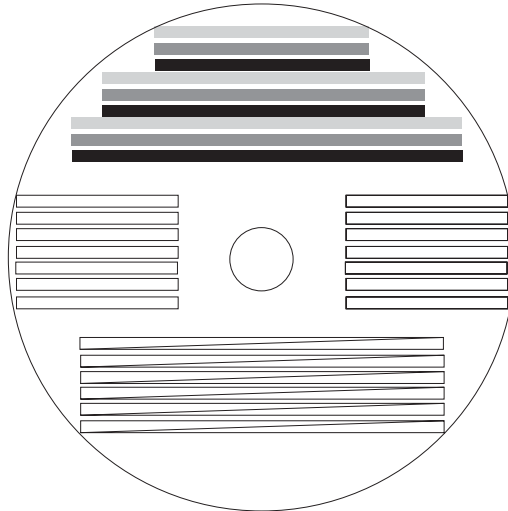

Select the **Clean** button to send a simple test pattern to the printer. Be sure to have a disc in the printer's input bin and the front cover closed. The test pattern, shown below, purges ink through nozzles of your ink cartridge to clear any blockages. The test pattern will show if the nozzles require any further cleaning.

If the Yellow, Magenta, Cyan, Light Magenta, Light Cyan or Black diagonal lines printed on the disc show breaks, repeat the cleaning procedure. If nozzles still appear to be clogged, remove the cartridge and gently wipe the nozzle area sideways with a clean water dampened cloth. If after several cleanings a color still does not appear on the test print, the cartridge may be damaged or empty and may need to be replaced. Select the Change button to install a fresh, new ink cartridge or to

switch back and forth between previously used cartridges. After the cartridge has been replaced according to the instructions on page 7, select either the New Color, New Black or Photo or Used Cartridge button accordingly. These selections are necessary for the printer to accurately keep track of ink cartridge ink levels.

---

### C. PRINTING A DISC

Now that you have hooked up the printer, loaded the print supplies, and installed the printer driver, you are ready to print your first disc. Follow these steps to print your first image:

1. Go to your favorite graphics application program. Or, install and open the SureThing CD Labeler software included with your printer.
2. Open or create the image file you wish to print. If using a program other than the included Windows CD creation software, you will need to create a custom page or canvas size in your program according to the type of label you intend to create. The following tips will help you do this:
  - If creating a label for a **CD**, set your page size to 119.7mm x 119.7mm. Although your image will appear square on screen, the printer driver will automatically crop your image to the round shape of a CD for printing. The driver will also automatically crop out the center 38.5mm of your image to accommodate a CD's non-printable center hub (more or less if you change the center size in the Calibration tab). If you would like to better visualize where the round outside edge and the round non-printable center of a CD will fall in relation to your image, simply draw one circle with a 119.7mm diameter and another with a 38.5mm diameter. Then, center both circles within your active page or canvas area. These circles will serve as a guide while designing your image. Be sure to delete these circles before printing.
3. Once you have created your image and are ready to print, select **Print Setup** (or the equivalent) from the program's File menu to verify that the printer driver settings are correct for your image. Be sure the proper Ink Cartridge

options are selected according to the supplies you have installed in the printer. Once the driver is set, select **Print** from the program's File menu.

4. The printer driver will then begin to process the image. Depending upon the size of the image and the processing speed of your computer, processing time can take from several seconds to a minute or so.
5. Once processing is complete, the printer will begin to print. Print time will vary depending on whether you are printing with color or monochrome cartridges and on which Print Quality setting you selected. When printing is complete, the Disc Tray will automatically open and remain fully extended until the next print job is received.

---

#### D. CREATING A PRINT FILE (\*.PRN)

If you are using the OptiEC Pro Printer 6 with a duplication system, it may be necessary to print your image to a \*.PRN file on your hard drive. This is also useful for a print job that doesn't change and has to be printed often. This is because a print (\*.PRN) file contains the bit-for-bit information that is to be printed to the disc surface.

A print file is created in most applications by selecting a **Print to File** option in the Print Dialog Window. If your application does not have a Print to File option, you must change the printing port under the printer properties to set it to File rather than a LPT or USB port. This is done as follows:

1. Click the **Start** button, point to Settings, and select Printers.
2. Right-click the OptiEC Pro Printer 6 icon from the Printers Folder and select properties.
3. Select the ports tab and select the "File" option.

You are now ready to create a print file. First, make certain you have your driver properties (i.e. cartridge type, print resolution, color matching, etc) set the way you want them. Please note

that a print file has all driver settings built into that file at the time of creation. Once this file is created it cannot be changed. For example, if a print file was created with the cartridge type set to color, you can only print using a color cartridge. If you change to a monochrome cartridge, the print file will not work. You would have to recreate the print file with the driver properties set to monochrome in order for it to work properly.

Once you are confident of your driver settings, simply click **Print**. When using Windows 2000 or XP you will be prompted for the name, but not the destination path. The file destination is determined by your operating system. To find the file after it is created, simply search for that file using the Find File feature found on the Start Menu. Each time a file is created it should be saved in this location. It does not matter where you save the file to, but you will want to name the file with the PRN file extension or it may not work properly.

---

#### E. CREATING PRN FILES IN SURETHING CD LABELER

Printing to a file is a good way to spool a print file for use with automated duplication.

- a. Open up SureThing CD Labeler
- b. Create or Open up an already created file.
- c. Go to **File** on the menu bar.
- d. Select **Print**.
- e. Select the **Advanced** button at the bottom left corner of the print window.
- f. Check the **Print to File** check box and select **OK**
- g. Select **OK** to print.
- h. When prompted to provide an Output Filename, type in a name that you want to give the PRN file (ex. test.prn). Make sure to type in the extension .prn when creating the output file. If you want to directly specify where you want to save the PRN file, you may directly specify it at this time (ex. C:\My Documents\test.prn). If you do not provide a path, the file will most likely be copied to the, **My Documents** folder. If not, you may search for it using the Search feature from your Start menu.

*Please Note: If you wish to print directly from SureThing, you will need to disable Print to File in the Advanced options.*

## Section 4: Interpreting the Printer's Indicator Lights

The **Power** and **Busy** LED indicator lights located on the top of the printer can tell you a lot about what is happening inside the printer. To accurately interpret what it means when these lights are on, off, or flashing, please refer to the following:

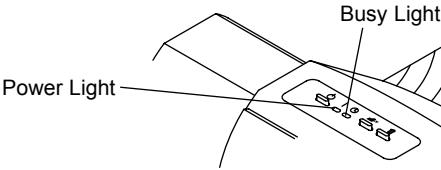

**Power Light** Ⓛ **Busy Light** **Printer**

Power Light	Busy Light	Printer
on solid	off	Is ready to receive a print job.
on solid	on solid	Is processing and printing an image.
on solid	blinking slowly	Has received a print job and is waiting for you to load CD media or has a print media jam.  If media loading is required, simply load media into the Disc Tray according to Section 2-C and press the  Disc Tray button to resume printing. If print media is jammed, clear the media from the printer and turn the printer OFF and ON to reset for the next print job.
both lights are blinking alternately with each other		Waiting for a cartridge to be installed and the Ink Cartridge button to be pressed.  See Section 2-B or 2-E for more information on changing or replacing ink cartridges.
on solid	flashing rapidly	The tray or the carrier has stalled. Turn the unit OFF and ON again. You may need to clear an obstruction such as a jammed disc.

**| Power Light**   **⌚ Busy Light**   **Printer**

flashing rapidly	on solid	Cartridge Problem. Either the wrong cartridge or no cartridge is installed. If the proper cartridge is installed, but the error continues, the printer may not be able to properly detect the cartridge. There is a multi-colored barcode label on the bottom of the ink cartridge which the printer uses to identify the cartridge. If this label is damaged, the cartridge may not be detected properly.
Both lights are flashing at the same time rapidly and the printer has paused.		Ink Low Warning. You can either replace the cartridge now (see Section 2-B or 2-E) or you can press the Disc Tray button to continue printing. Note: If you do replace the cartridge now then the ink levels will be cleared. (It assumes you replaced with a fresh cartridge.) If you instead press the Disc Tray button to continue then the ink levels will <u>not</u> be cleared and you will not be warned again until a new cartridge is installed.
Both lights are blinking at the same time in this sequence: five blinks, pause, repeat . . .		Waiting for you to specify if you've installed a new COLOR, Black or Photo Cartridge. Press the Power button to specify a new COLOR Cartridge or press the Ink Cartridge button to specify a new Black or Photo Cartridge. You will get to this point by first pressing the Ink Cartridge button, installing a new cartridge and then <i>pressing and holding</i> the ink cartridge button. See Section 2-E for more details.

## Section 5: Maintaining the Printer

The OptiEC Pro Printer 6 is designed to require very little maintenance. Nevertheless, there are a few procedures you can perform on a regular basis or as needed to ensure your printer's best performance.

---

### A. CLEANING THE INK CARTRIDGE NOZZLES

It may be necessary to clean the ink cartridge nozzles if the printer does not seem to be laying down ink evenly or if you suspect an ink cartridge nozzle has become slightly dried out or clogged. Refer to the cleaning procedure explained within the **Cartridge** button description of Section 3-B to clean the cartridge nozzles.

---

### B. CLEANING THE DISC TRAY AND PRINTER CASING

If ink gets on the printer's Media Tray, it may stain if left on the tray too long. To avoid this, simply wipe off any ink from the Media Tray as soon as you notice it. Use a lint-free cloth *slightly* moistened with water to wipe off the Media Tray. If necessary, use these same items to wipe off the outside casing of the printer. **Always disconnect your printer's power cord before cleaning.** Resume printer operation only after the printer is completely dry.

---

### C. CLEARING A MEDIA JAM

If Media becomes jammed inside the printer, first press the  Media Tray button to try and eject the media. If this does not work, turn the printer power OFF and gently try to clear or remove the media manually.

---

### D. TECHNICAL SUPPORT

If you have difficulty operating your OptiEC Pro Printer 6, the procedures in this manual should, in most cases, solve the problem. If you still have difficulty, contact the technical support number listed on the insert included in the supply pack.

## Section 6: Technical Specifications

<b>Model:</b>	OptiEC Pro Printer 6
<b>Print Method:</b>	Ink-Jet
<b>Printing Resolution:</b>	4800 x 1200, 2400 x 1200 dpi, 1200 x 1200 dpi or 600 x 600 dpi (driver selectable)
<b>Colors:</b>	About 34 seconds for 100%, full-color coverage, 16.7 million with black monochrome
<b>Ink Types:</b>	Dual-cartridge 3-Color (C, M, Y), either Photo Color (Kmc) or Black Monochrome (K)
<b>Color Matching:</b>	PrimaColor™ color matching software included
<b>Media Types:</b>	Printable-surface 120mm CD-R or DVD-R; also supports 58mm x 86mm printable-surface business card CDs with optional adapter kit (sold separately)
<b>Printer Drivers:</b>	Windows 2000/XP
<b>Data Interfaces:</b>	USB-only PCs
<b>Minimum System</b>	Pentium®-class computer or better, 64MB RAM, 100MB
<b>Requirements:</b>	free hard drive space
<b>Control Interface:</b>	TTL-level signals for busy printing, tray open/close, etc.; available on rear-panel 6-pin mini-DIN connector
<b>Label Editing Software:</b>	SureThing™ First Edition Software for Windows included
<b>Maximum Print Width:</b>	4.72" (120 mm)
<b>Electrical Ratings:</b>	12 VDC, 3.5A
<b>Adapter Types:</b>	100-240 VAC
<b>Certifications:</b>	UL, UL-C, CE, FCC Class B
<b>Dimensions:</b>	7.5"H x 17"W x 10.5"D (190mmH x 432mmW x 266mmD)
<b>Weight:</b>	9.3lbs (4.3 kg)

## Appendix A: Interfacing Information

---

### A. INTRODUCTION

The OptiEC Pro Printer 6 is equipped with a standard USB port. This communication port is the means through which the printer receives data from your computer. Contact technical support if you need more information on the USB port specifications.

## B. 6-PIN MINICIRCULAR AUXILIARY INTERFACE

The 6-pin minicircular auxiliary interface is used for connecting the printer with auxiliary equipment such as a CD transporter/ auto-loader.

Pin assignments are as follows:

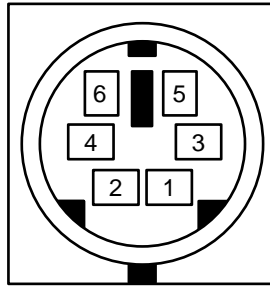

Uses 5v logic @ 5mA

Pin Number	Signal Description
1	Busy - Output is high when the printer is busy or moving the Disc Tray.
2	Tray Out - Output is high when the Disc Tray is fully ejected.
3	Tray In - Output is high when the Disc Tray is fully inserted.
4	CD In - Output is high when the Disc Tray is in and a CD is present.
5	Ground.
6	Tray In/Out - A low input moves the Disc Tray in if it is out, and out if it is in.

**TABLE A-1: Auxiliary Interface Pin Assignments**

*NOTE: Pins 1-4 are low if the printer is plugged in but the power has been turned off using the printer's Power Button*

## Index

<b>Algebraic</b> .....	15
<b>Auxiliary Port</b> .....	3
<b>Busy Light</b> .....	2
<b>Calibrate</b> .....	17
<b>Cartridge</b>	
Installing .....	4
Reorder Numbers .....	1
Replacing .....	7
<b>CDs</b> .....	4
<b>Color Matching</b> .....	15
<b>Disc Tray</b> .....	1, 2
<b>Disc Tray Button</b> .....	2
<b>Ink Cartridges</b> .....	4
<b>Ink Cartridge Button</b> .....	2
<b>Ink Saturation</b> .....	16
<b>Interface Port</b> .....	3
<b>Media</b> .....	4, 6, 14
<b>Print Quality</b> .....	4, 15, 22
<b>Printable CDs</b> .....	4
<b>Printer Driver</b> .....	4, 8, 11
<b>Power Button</b> .....	2
<b>Power Light</b> .....	2
<b>Self Test</b> .....	7
<b>Technical Support</b> .....	26

Printed in the United States of America  
P/N 510901